

# the Water Grabber® "Bull Dog"™

**Basement Technologies**  
The Basement Specialists™  
Basement Waterproofing

**The Pump That Does Not Look Like A Pump**

**Install Value in Your Home!**



Homes are built square, level and plumb ... **not** circular. Why have a circular pump liner that looks like a pump? Introducing the patent pending Basement Technologies Water Grabber® Bulldog™!

**Revolutionizing the Basement Waterproofing Industry**



Standard top discharge through the lid. Shown with our optional "Ranger"™ drain.

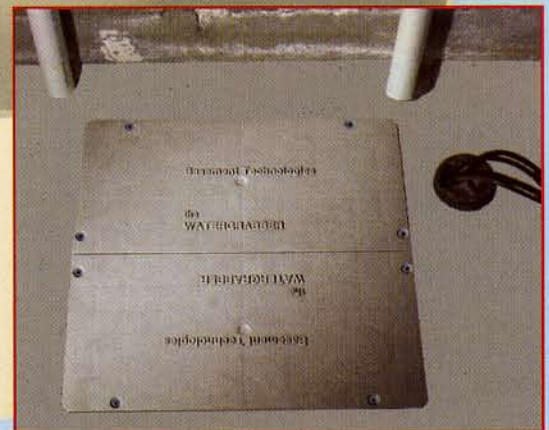

Solid lid with hidden pipes and wires.

**Improving Basement Waterproofing From The Ground Up™**

# Your home should be functional and present a who wants a sump pump

**Basement Technologies** is proud to introduce our revolutionary new Water Grabber® - the "Bull Dog™"! Our unique patent pending sump pump system represents an innovative alternative to the common circular pumping unit. Our "liner" which houses the pump in and under the ground, is SQUARE! Basement Technologies' research and development department continues to "think outside the box", and in this case, "inside the box" and as a result...the new Water Grabber® "Bull Dog™" has arrived!

**The pump that does not look like a pump.**



## Why would we call our revolutionary new product the "Bull Dog"?

...because that's exactly what it is! **The Bull Dog breed combines characteristics like tenacity, loyalty, toughness and veracity**... all of which define our new patent pending sump pump with the added benefits of backups and secondary pumps and configurations ... this all can be accomplished without changing round liners or having ugly "buckets" that look like sump pumps.



"Cut away" view of the Double Bull Dog™ configuration with a Pon1® Battery Back-up and sealed lid. One pump is raised above the other on a patent pending special interior shelf with the wires hidden.

Most people are familiar with the old circular design of sump pumps that other waterproofing companies seem content to use. Basement Technologies recognizes that to be a leader in the basement waterproofing industry, one must continually improve old products and introduce more efficient new ones.

The circular pump liner is simply not as aesthetically pleasing or as effective as our new liner...Our answer to this out-of-style look and function is the Water Grabber® "Bull Dog™".

**Your basement was built square, level, and plumb - not circular, so why have a circular liner in a square corner which looks like a plumbing product?** Historically, a sump pump is located on a straight wall or in a corner. Doesn't it make sense to install a sump pump that fits snugly and attractively in your basement...and emulates a building product look? - not a sump pump!



The option for hidden pipes is in great demand. Shown with our optional "Ranger™" drain.

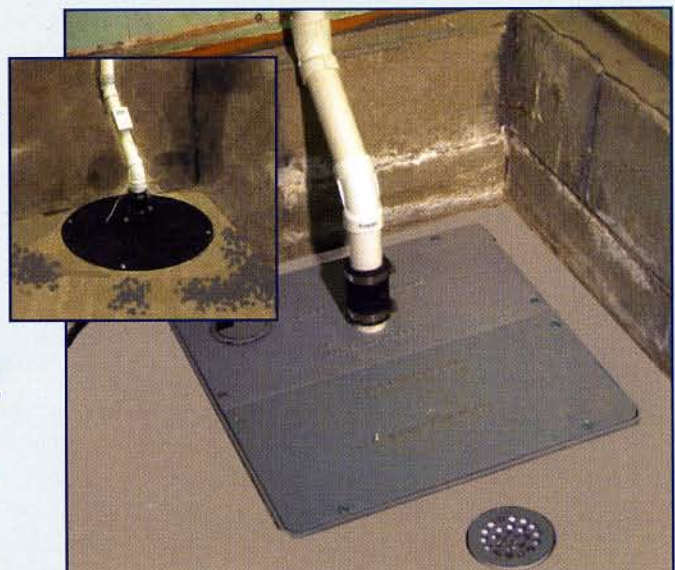

A typical Basement Technologies installation. Shown with our optional "Ranger™" drain.

# an attractive appearance from top to bottom... to look like a sump pump?



Typical sump installations



The neat clean look of the Water Grabber® "Bull Dog™" with a Pon® battery backup and optional "Ranger™" drain.

The most effective waterproofing systems are installed in the inside of the home. When interior drainage systems are installed, they need a central ejection device - a way to get the water from the basement to the outside of the home. Our patent pending Water Grabber® "Bull Dog™" is the heart and lungs of

our Water Trek Aqua Route® perimeter system. The Water Grabber® "Bull Dog™" consists of a patent pending drilled polyethylene basin with a split lid. We use 3/4" gravel to surround the basin to help filter the water. The pumping device is a Barnes 1/3 H.P. cast iron pump rated at approximately 3,000 gallons per hour and will pump

up to 1/2" solids, with optional 1/2 and 3/4 H.P. pumps readily available for real problem water.

**Independent and company tests indicate that this pump is the best in the industry.**

We install our alarm, the "Grabber Pal", in the basin to alert you if the pump has a mechanical problem or was unplugged accidentally. This alarm is float activated and far superior to

sensor type alarms which other companies carry. We use a special rubber fitting called "The Silencer™" over or under the lid dependent on a side or top discharge to quiet the already quiet pump. We normally discharge the water to the exterior lawn, approximately 10 to 20 feet from the base of the home, to our special "Bubbler Poi™". We always install our patented Freeze Stop™ Discharge Line Protector, with 360° of protection, and guarantees our sump pump discharge line will always discharge to the outside and never back up.

**Why put a sump pump in a basement if it looks like a sump pump?** Perceptions of potential home buyers are, "sump pumps are ugly". Basement Technologies new patent pending unique design hides your pump in a liner that is extraordinarily attractive. The liner is the "housing" that holds our superior pumps under the ground.

**There are none like it in the basement waterproofing industry and no other basement waterproofing company can offer a sump liner like it!**

**Patent pending for a reason - It just works better!**

**Basement Technologies**  
The Basement Specialists™  
Basement Waterproofing

Revolutionizing the Basement Waterproofing Industry™



# The Water Grabber® Bull Dog™

**Basement Technologies**  
The Basement Specialists™  
Basement Waterproofing

**NEW**

## OPTIONAL CONFIGURATIONS

**... solutions for any basement waterproofing need**

### Option 1 - Classic Bull Dog™

(Optional Powerguard Battery Backup Available for Two (2) Way Protection)

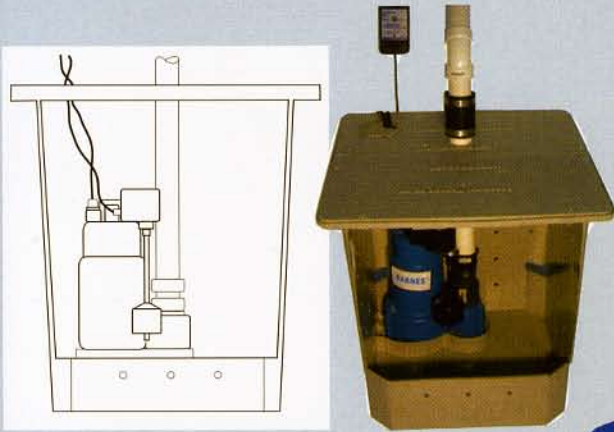

### Option 2 - Classic Bull Dog™ w/Side Discharge

(Optional Powerguard Battery Backup Available for Two (2) Way Protection)

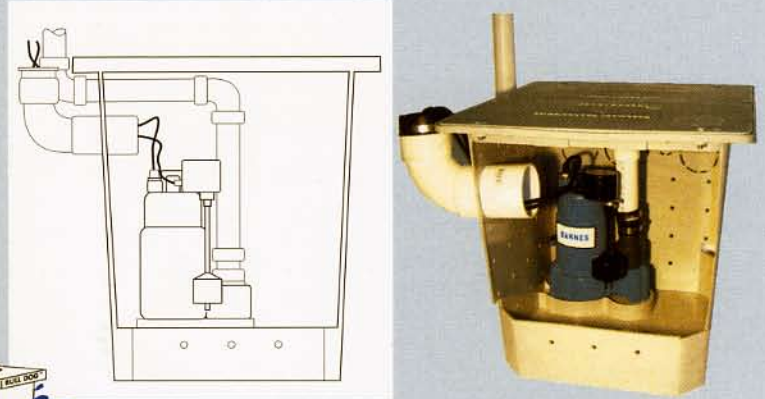

Hides Pipes and Wires for a Clean No Sump Look

## Improving Basement Waterproofing from the Ground Up™

### Option 3 - Classic Bull Dog™ w/Poni®

(Optional Powerguard Battery Backup Available for Three (3) Way Protection)

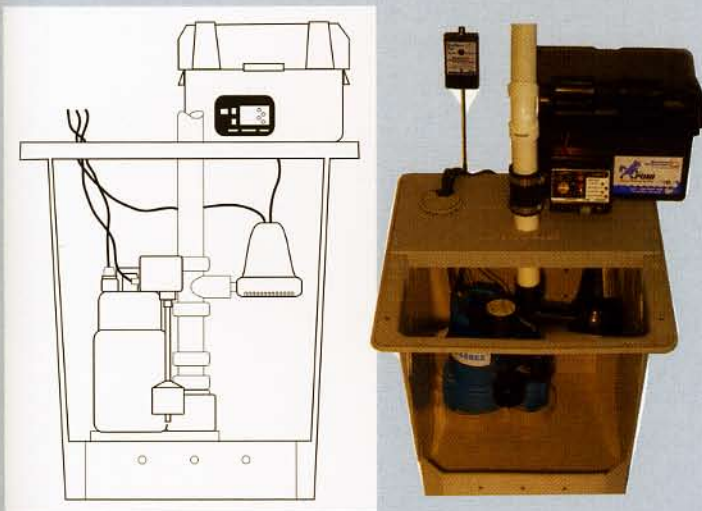

### Option 4 - Classic Bull Dog™ w/Poni® Side Discharge

(Optional Powerguard Battery Backup Available for Three (3) Way Protection)

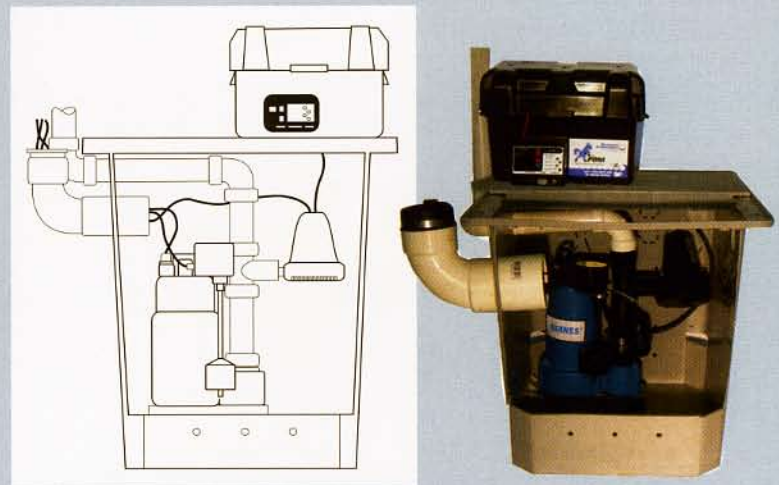

Hides Pipes and Wires for a Clean No Sump Look

**“Where Design Innovation Keys Our Superior Products™”**

**NEW**

# OPTIONAL CONFIGURATIONS

**Basement Technologies**  
The Basement Specialists™  
Basement Waterproofing

**... solutions for any basement waterproofing need**

## Option 5A - Double Bull Dog™

(Optional Powerguard Battery Backup Available for Three (3) Way Protection)

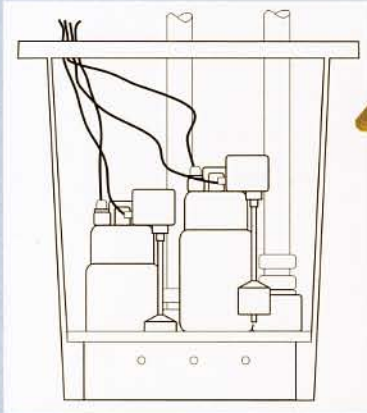

## Option 5B - Double Bull Dog™ Side Discharge

(Optional Powerguard Battery Backup Available for Three (3) Way Protection)

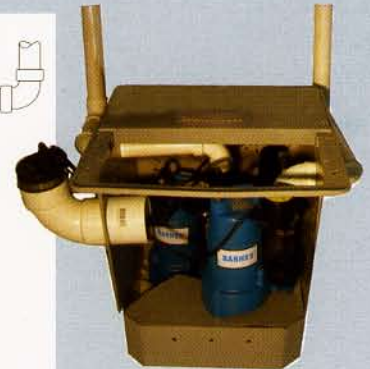
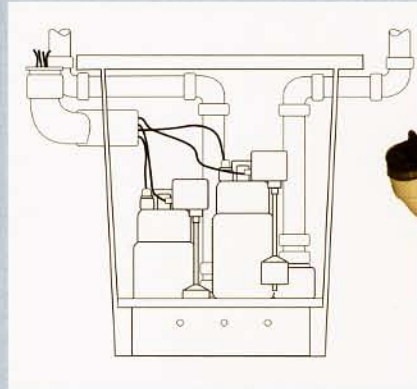

Hides Pipes and Wires for a Clean No Sump Look

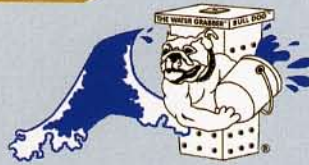

# Improving Basement Waterproofing from the Ground Up™

## Option 6A - Double Bull Dog™ w/Poni®

(Optional Powerguard Battery Backup Available for Four (4) or Five (5) Way Protection. The 5 Way Protection Package is Also Known as **PLATINUM** Double Bull Dog™ w/Poni®)

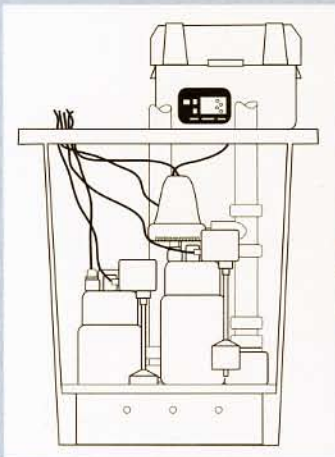

## Option 6B - Double Bull Dog™ w/Poni® Side Discharge

(Optional Powerguard Battery Backup Available for Four (4) or Five (5) Way Protection. The 5 Way Protection Package is Also Known as **PLATINUM** Double Bull Dog™ w/Poni® Side Discharge)

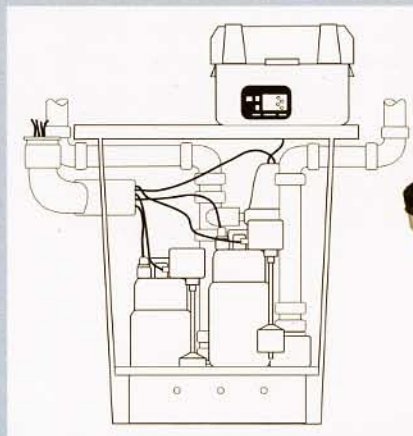

Hides Pipes and Wires for a Clean No Sump Look

**"Where Design Innovation Keys Our Superior Products™"**

**Our patent pending Water Grabber® Bull Dog™ revolutionary liner... the “no sump pump look”.**

The most innovative design change the industry has experienced... and the Water Grabber® Bull Dog™ is adaptable to several pump configurations. The built in sump stand at the bottom of the liner virtually eliminates stone and dirt infiltration through the pumping unit. An optional raised stand for a secondary pump is also available. Our new patent pending Water Grabber® Bull Dog™ offers virtually unlimited options for pumps and backups.



Standard installation with top discharge and our optional “Ranger™” drain.



The “Double Bull Dog™” Double Pump/Double Discharge Standard Installation with our optional “Ranger™” drain.

*Is your sump pump outdated and ineffective? **We Can Help!***



Single “Bull Dog™” with side discharge. Sealed solid lid for easy “hiding” under carpet or flooring.

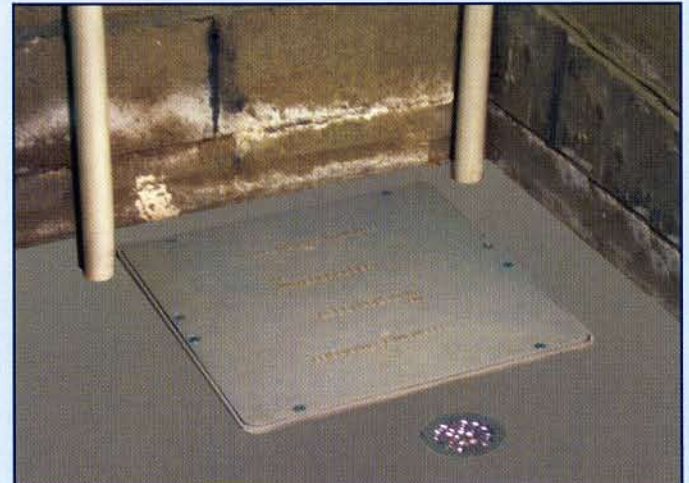

The neat look of a Double “Bull Dog™” Side Discharge/Double Pump solid lid. Added security and neat “no sump” look with our optional “Ranger™” drain.

**Patent pending for a reason – It just works better!**